

# 上汽大众汽车有限公司车辆识别代号系统

附件1

## FAHRZEUG-IDENTIFIZIERUNGSNUMMER

### FÜR SAIC VOLKSWAGEN

版本: 4.45  
VERSION:

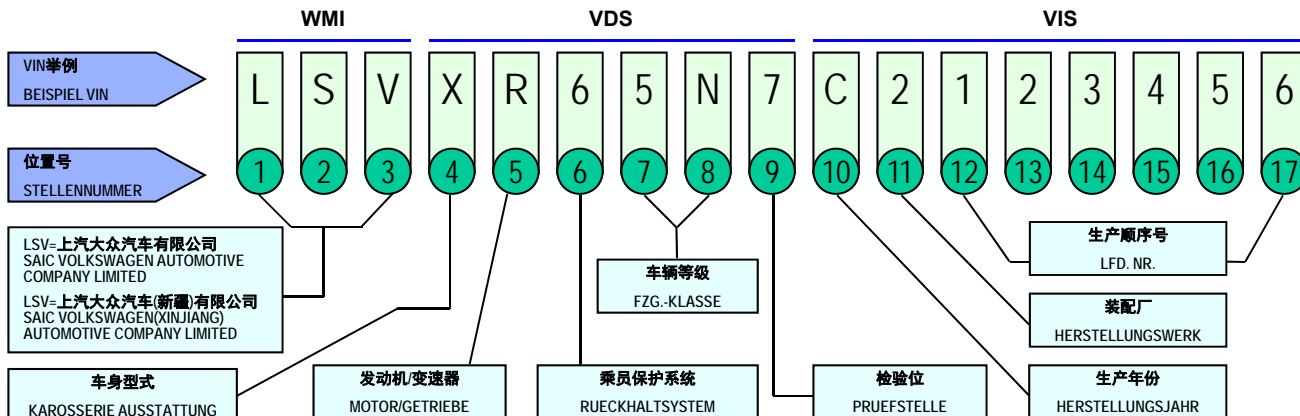

4 车身型式 KAROSSERIE AUSSTATTUNG
A K8B-4门折背式车身 (Fleet) STUFENHECK, 4 TÜREN (Fleet)
B K8D-4门直背式车身 VARIANT, 4 TÜREN
C K8L-4门加长型折背式车身 STUFENHECK-LANGER RADSTAND, 4 TÜREN
D K8L-4门加长型折背式车身 (GP) STUFENHECK-LANGER RADSTAND, 4 TÜREN (GP)
E K8L-4门加长型折背式车身 (GP1) STUFENHECK-LANGER RADSTAND, 4 TÜREN (GP1)
F K8G-4门短背式车身 (Monte Carlo) KURZHECK, 4 TÜREN (Monte Carlo)
G K8G-4门短背式车身 (GP) KURZHECK, 4 TÜREN (GP)
H K8L-4门加长型折背式车身 (GP11) STUFENHECK-LANGER RADSTAND, 4 TÜREN (GP11)
J K8L-4门加长型折背式车身 (GP1V) STUFENHECK-LANGER RADSTAND, 4 TÜREN (GP1V)
K K8G-2门短背式车身 KURZHECK, 2 TÜREN
L K8P-MPV 4门车身 (5座) (Classic) MPV, 4 TÜREN (5 SITZE) (Classic)
M K8P-MPV 4门车身 (7座) (Classic/Cross) MPV, 4 TÜREN (7 SITZE) (Classic/Cross)
N K8B-4门折背式车身 (GP/PA) STUFENHECK, 4 TÜREN (GP/PA)
P K8G-4门短背式车身 (Cross/Scout/RS/Sport) KURZHECK, 4 TÜREN (Cross/Scout/RS/Sport)
R K8P-MPV 4门车身 (GP 5座) MPV, 4 TÜREN (GP 5SITZE)
S K8P-MPV 4门车身 (GP/PA 7座) MPV, 4 TÜREN (GP/PA 7SITZE)
T K8L-4门加长型折背式车身 (GPV) STUFENHECK-LANGER RADSTAND, 4 TÜREN (GPV)
U K8P-SUV 4门加长型车身 (5座) SUV, LANGER RADSTAND, 4 TÜREN (5SITZE)
V K8P-MPV 4门车身 (GP 5座 TAXI / 4座) MPV, 4 TÜREN (GP 5 SITZE TAXI / 4 SITZE)
W K8B-4门折背式车身 (GP11/PA11) STUFENHECK, 4 TÜREN (GP11/PA11)
X K8P-SUV 4门加长型车身 (GP/City/R-Line/Coupe/GT PA) SUV, LANGER RADSTAND, 4 TÜREN (GP/City/R-Line/Coupe/GT PA)
Y K8P-SUV 4门加长型车身 (外挂备胎/5/6座 PA) SUV, LANGER RADSTAND, 4 TÜREN (Mit Reserverad/5/6SITZE PA)
Z K8P-SUV 4门加长型车身 (外挂备胎/City/7座 PA) SUV, LANGER RADSTAND, 4 TÜREN (Mit Reserverad/City/7SITZE PA)
0 K8G-4门短背式车身 (Cross/Scout/RS/Sport GP) KURZHECK, 4 TÜREN (Cross/Scout/RS/Sport GP)
1 K8P-SUV 4门加长型车身 (6座) SUV, LANGER RADSTAND, 4 TÜREN (6SITZE)
2 K8P-SUV 4门加长型车身 (7座) SUV, LANGER RADSTAND, 4 TÜREN (7SITZE)
3 K8P-MPV 4门车身 (6座) MPV, 4 TÜREN (6 SITZE)
4 K8P-MPV 4门车身 (5座/Cross) MPV, 4 TÜREN (5 SITZE/Cross)
5 K8C-SUV (COUPE/GT) 4门加长型车身 SUV (COUPE/GT), LANGER RADSTAND, 4 TÜREN
6 K8P-MPV 4门车身 (6座/Cross) MPV, 4 TÜREN (6 SITZE/Cross)
7 K8P-SUV 4门加长型车身 (7座/R-Line/Spacial-Line) SUV, LANGER RADSTAND, 4 TÜREN (7 SITZE/R-Line/Spacial-Line)

5 发动机/变速器 MOTOR/GETRIEBE	
<b>车型系列: 上海桑塔纳轿车 SANTANA</b> 上海桑塔纳旅行轿车 SANTANA VARIANT 上海桑塔纳2000轿车 SANTANA 2000 上海桑塔纳3000轿车 SANTANA 3000	<b>车型系列: 上海波罗轿车 POLO</b> A BCC (036.P) / GET (02.T.Z) [FCU (02.T.Z)] B BCC (036.P) / GCU (001.H) [ESK (001.H)] C BCD (06A.6) / GEV (02.T.U) [FXP (02.T.U)] D BCC (036.P) / GRZ (02.T.Z) E BCC (036.P) / GJG (001.H) F BCD (06A.6) / HGB (09G.N) G BMG (03C.1) / HGF (02.T.U) H BMG (03C.1) / HTJ (09G.R) J BMH (03C.2) / GSK (02.T.U) K BMH (03C.2) / HTK (09G.R) L CDD (03C.1) / JHU (02.T.U) M CDD (03C.1) / HTJ (09G.R) N CDE (03C.2) / JGZ (02.T.R) P CDE (03C.2) / HTK (09G.R) R CDD (03C.1) / LUZ (02.T.U) [JHU (02.T.U)] S CDD (03C.1) / KGF (09G.R) [HTJ (09G.R)] T CDE (03C.2) / LUJ (02.T.R) [JGZ (02.T.R)] U CDE (03C.2) / KGG (09G.R) [HTK (09G.R)] V CDD (03C.1) / LUZ (02.T.U) [JHU (02.T.U)] EHPS 1 BMG (03C.1) / HGF (02.T.U) OBD 2 BMG (03C.1) / HTJ (09G.R) OBD 3 BMH (03C.2) / GSK (02.T.U) OBD 4 BMH (03C.2) / HTK (09G.R) OBD
<b>车型系列: 上海帕萨特轿车 PASSAT</b> A ANQ (06B.H) / DWB (01W.D) [FSN (0A9.A)] B ANQ (06B.H) / DMU (01N.A) [EPT (01N.A)] C AWL (06B.A) / EZS (01V.J) D AWL (06B.A) / EMG (01W.V) [GFS (01W.V)] E BBG (078.2) / EZY (01V.B) G BFF (06B.L) / EMV (01W.4) [GFZ (01W.4)] H BFF (06B.L) / EPT (01N.A) J 38K / FHN (01W.6) L BGC (06B.M) / EZS (01V.J) M BGC (06B.M) / EMG (01W.V) [GFS (01W.V)] N BNL (06B.L) / EMV (01W.4) P BNL (06B.L) / EPT (01N.A) R CED (06B.M) / JEC (01V.J) S CED (06B.M) / KMA (01W.V) T CED (06B.M) / JEC (01V.J) [JET (01V.J)] OBD U CED (06B.M) / GFY (01W.3) [KMA (01W.V)] OBD V BPZ (03G.5) / GGB W SL1211 (FCV) X CMY (06B.M) / JEC (01V.F) OBD Y CMY (06B.M) / GFY (01W.V) OBD 1 BGC (06B.M) / EZS (01V.J) OBD 2 BGC (06B.M) / EMG (01W.V) [GFS (01W.V)] OBD 3 BNL (06B.L) / EMV (01W.4) OBD 4 BNL (06B.L) / EPT (01N.A) OBD 5 BBG (078.2) / JED (01V.B) [EZY (01V.B)] OBD	<b>车型系列: 上海高尔轿车 GOL</b> A BHJ (050.C) / GPJ (013.D) B BRZ (050.D) / GPJ (013.D) C BRZ (050.D) / GPJ (013.D) OBD
<b>车型系列: 大众汽车(VOLKSWAGEN) TOURAN 多用途乘用车</b> A CFU (06A.9) / HJK (0A4.D) (国IV) B CFU (06A.9) / HTR (09G.G) [HHH (09G.G)] (国IV) C BPL (06A.9) / HJK (0A4.D) D BPL (06A.9) / HTR (09G.G) [HHH (09G.G)] E BPL (06A.9) / HJK (0A4.D) OBD F BPL (06A.9) / HTR (09G.G) [HHH (09G.G)] OBD G BJZ (06B.L) / GUG (0AH.C) [KLK (0AH.C)] H BJZ (06B.L) / HTQ (09G.G) [GKC (09G.G)] J BJZ (06B.L) / GUG (0AH.C) [KLK (0AH.C)] OBD K BJZ (06B.L) / HTQ (09G.G) [GKC (09G.G)] OBD L CSR (04E.3) / QTV (0AH.M) (国五) M CGZ (06G.C) / KLK (0AH.C) OBD N CGZ (06G.C) / KGM (09G.G) OBD P CFB (03C.M) / LEL (0A4.D) R CFB (03C.M) / MPH (0AM.J) S CFB (03C.M) / MPH (0AM.J) YH T CFB (03C.M) / LEL (0A4.D) (京V) U CFB (03C.M) / NTP (0AM.J) (京V) V CFB (03C.M) / LEL (0A4.D) (国五) W CFB (03C.M) / NTP (0AM.J) (国五) X CFB (03C.M) / LEL (0A4.D) (国五) Y CFB (03C.M) / NTP (0AM.J) (国五) Z CSR (04E.3) / QYM (0AH.M) (国五) (RowI)	

FAHRZEUG-IDENTIFIZIERUNGSNUMMER

FÜR SAIC VOLKSWAGEN

版本: 4.45
VERSION:

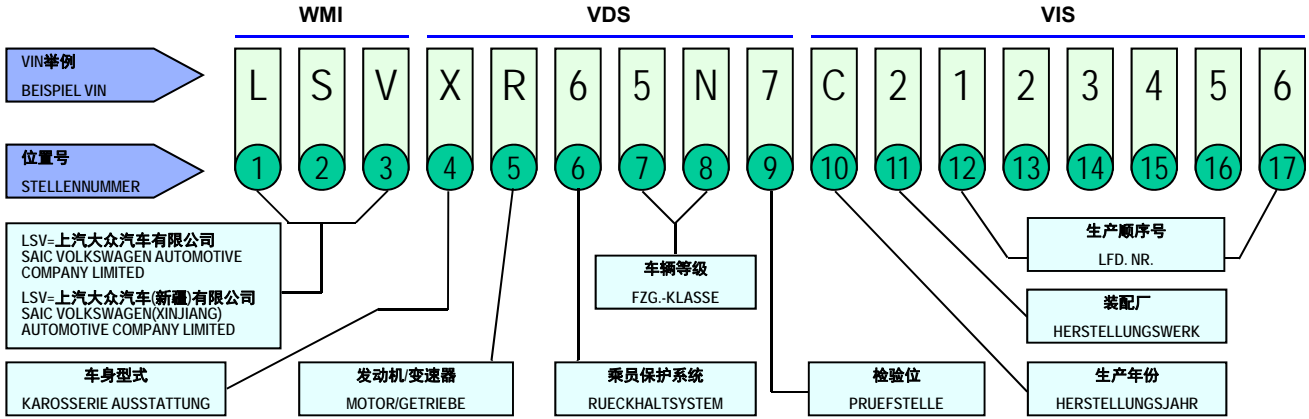
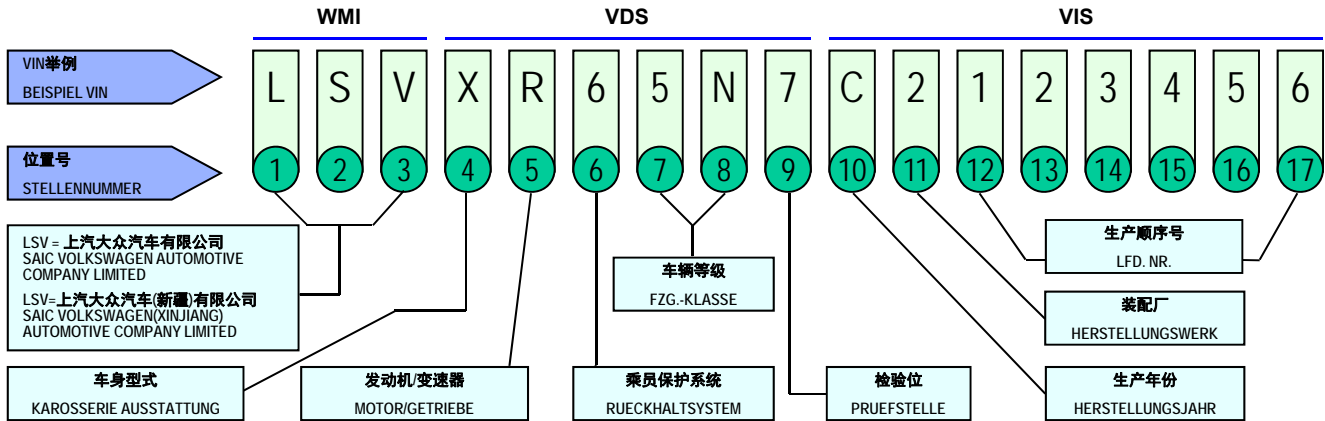

Table with 3 columns: 5 发动机/变速器 (MOTOR/GETRIEBE), 乘员保护系统 (RUECKHALTSYSTEM), and 生产年份 (HERSTELLUNGSJAHR). It lists various vehicle models and their corresponding VIN codes for different configurations.

FAHRZEUG-IDENTIFIZIERUNGSNUMMER

FÜR SAIC VOLKSWAGEN

版本: 4.45  
VERSION:



5 发动机变速器 MOTOR/GETRIEBE		
<p><b>车型系列: 大众汽车(VOLKSWAGEN)PASSAT轿车</b></p> <p>A CFB (03C.M) / LEL (0A4.D)</p> <p>B CFB (03C.M) / MPO (0AM.S)</p> <p>C CEA (06J.4) / NKM (09G.L)</p> <p>D CEA (06J.4) / MPJ (0AM.J)</p> <p>E CGM (06J.F) / MSX (02E.C) [ NLQ (02E.C) ]</p> <p>F CNG (03H.F) / NJH (02E.M) [ NLW (02E.M) ]</p> <p>G CFB (03C.M) / LEL (0A4.D) YH</p> <p>H CEA (06J.4) [ CDA (06J.4) ] / NTO (0AM.J) (京V)</p> <p>J CGM (06J.F) / NLQ (02E.C) (京V)</p> <p>K CNG (03H.F) / NLW (02E.M) (京V)</p> <p>L CFB (03C.M) / LEL (0A4.D) (京V)</p> <p>M CFB (03C.M) / NTZ (0AM.S) (京V)</p> <p>N CFB (03C.M) / NTZ (0AM.S) (BlueMotion) (京V)</p> <p>P CFB (03C.M) / LEL (0A4.D) (国五<sup>1</sup>)</p> <p>R CFB (03C.M) / NTZ (0AM.S) (国五<sup>2</sup>)</p> <p>S CFB (03C.M) / NTZ(0AM.S) (BlueMotion) (国五<sup>1</sup>)</p> <p>T CEA (06J.4) / NTO (0AM.J) (国五<sup>1</sup>)</p> <p>U CGM (06J.F) / NLQ (02E.C) (国五<sup>1</sup>)</p> <p>V CNG (03H.F) / NLW (02E.M) (国五<sup>1</sup>)</p> <p>W CFB (03C.M) / LEL (0A4.D) (国五<sup>2</sup>)</p> <p>X CFB (03C.M) / NTZ (0AM.S) (国五<sup>2</sup>)</p> <p>Y CFB (03C.M) / NTZ (0AM.S) (BlueMotion) (国五<sup>2</sup>)</p> <p>Z CEA (06J.4) / NTO (0AM.J) (国五<sup>2</sup>)</p> <p>0 CGM (06J.F) / NLQ (02E.C) (国五<sup>2</sup>)</p> <p>1 CNG (03H.F) / POG (02E.M) (国五<sup>2</sup>)</p> <p>4 CSS (04E.H) / OGA (0A4.C) [ RNG (0A4.C) ] SSR (国五<sup>2</sup>)</p> <p>5 CSS (04E.H) / ROK (0CW.C) SSR (国五<sup>2</sup>)</p> <p>6 CEA (06J.4) / NKM (09G.L) (国五<sup>2</sup>)</p> <p>7 DBH (06K.G) / RFT (0DE.A) SSR (国五<sup>2</sup>)</p> <p>9 DBJ (06K.H) / RFT (0DE.A) SSR (国五<sup>2</sup>)</p>	<p>Z CSR (04E.3) / QAA (02T.R) (国五<sup>2</sup>)</p> <p>0 CSR (04E.3) / PLS (09G.P) (国五<sup>2</sup>)</p> <p>1 CSS (04E.H) / QJM (0AM.V) (国五<sup>2</sup>)</p> <p>2 CSR (04E.3) / PLS (09G.P) (国五<sup>2</sup>) (AQ160-ECO-Rowi)</p> <p>3 CSR (04E.3) / QAA (02T.R) (国五<sup>2</sup>) (Rowi)</p> <p>4 DAH (04E.1) / QNM (02T.K) (国五<sup>2</sup>) (Rowi)</p> <p>5 DAH (04E.1) / PRZ (09G.R) (国五<sup>2</sup>) (Rowi)</p> <p>6 DLX (04E.8) / SJZ (02T.S) SSR (国五<sup>2</sup>)</p> <p>7 DLX (04E.8) / SXK (09G.R) SSR (国五<sup>2</sup>)</p> <p><b>车型系列: 大众汽车(VOLKSWAGEN)SANTANA轿车</b></p> <p>A CKA (04E.1) / NJS (02T.V) (国IV)</p> <p>B CPD (04E.3) / NJV (02T.R) (国IV)</p> <p>C CPD (04E.3) / NMT (09G.R) (国IV)</p> <p>D CKA (04E.1) / NJS (02T.V) (京V)</p> <p>E CPD (04E.3) / NJV (02T.R) (京V)</p> <p>F CPD (04E.3) / NMT (09G.R) (京V)</p> <p>G CPD (04E.3) / PLS (09G.P) (国IV)</p> <p>H CPD (04E.3) / PLS (09G.P) (京V)</p> <p>J CUC (04E.4) / PCD (02T.K) (两用燃料) (国IV)</p> <p>K CKA (04E.1) / NJS (02T.V) (国五<sup>1</sup>)</p> <p>L CPD (04E.3) / NJV (02T.R) (国五<sup>1</sup>)</p> <p>M CPD (04E.3) / NMT (09G.R) (国五<sup>1</sup>)</p> <p>N CPD (04E.3) / PLS (09G.P) (国五<sup>1</sup>)</p> <p>P CKA (04E.1) / NJS (02T.V) (国五<sup>2</sup>)</p> <p>R CPD (04E.3) / NJV (02T.R) (国五<sup>2</sup>)</p> <p>S CPD (04E.3) / NMT (09G.R) (国五<sup>2</sup>)</p> <p>T CPD (04E.3) / PLS (09G.P) (国五<sup>2</sup>) AQ160</p> <p>U CST (04E.H) / QFP (0AM.V) (国五<sup>2</sup>)</p> <p>V CUC (04E.4) / PCD (02T.K) (两用燃料) (国五<sup>2</sup>)</p> <p>W CST (04E.H) / QFP (0AM.V) SSR (国五<sup>2</sup>)</p> <p>X CKA (04E.1) / NJS (02T.V) (国五<sup>2</sup>) (Rowi)</p> <p>Y CPD (04E.3) / NJV (02T.R) (国五<sup>2</sup>) (Rowi)</p> <p>Z CPD (04E.3) / PLS (09G.P) (国五<sup>2</sup>) (AQ160-ECO)</p> <p>0 CPD (04E.3) / PLS (09G.P) (国五<sup>2</sup>) (AQ160-ECO-Rowi)</p> <p>1 DLX (04E.8) / SJZ (02T.S) SSR (国五<sup>2</sup>) (Rowi)</p> <p>2 DLX (04E.8) / SXK (09G.R) SSR (国五<sup>2</sup>) (Rowi)</p> <p>3 DLX (04E.8) / SJZ (02T.S) SSR (国五<sup>2</sup>)</p> <p>4 DLX (04E.8) / SXK (09G.R) SSR (国五<sup>2</sup>)</p> <p>5 DLF (04E.8) / SJZ (02T.S) SSR (国六) (Rowi)</p> <p>6 DLF (04E.8) / SXK (09G.R) SSR (国六) (Rowi)</p> <p>7 DLF (04E.8) / SJZ (02T.S) SSR (国六)</p> <p>8 DLF (04E.8) / SXK (09G.R) SSR (国六)</p>	<p>M CPD (04E.3) / NMT (09G.R) (国五<sup>1</sup>)</p> <p>N CPD (04E.3) / PLS (09G.P) (国五<sup>1</sup>)</p> <p>P CKA (04E.1) / NJS (02T.V) (国五<sup>1</sup>)</p> <p>R CPD (04E.3) / NJV (02T.R) (国五<sup>1</sup>)</p> <p>S CPD (04E.3) / NMT (09G.R) (国五<sup>1</sup>)</p> <p>T CPD (04E.3) / PLS (09G.P) (国五<sup>1</sup>)</p> <p>U CKA (04E.1) / NJS (02T.V) (国五<sup>1</sup>) (Rowi)</p> <p>V CPD (04E.3) / NJV (02T.R) (国五<sup>1</sup>) (Rowi)</p> <p>W CPD (04E.3) / PLS (09G.P) (国五<sup>1</sup>) (AQ160-ECO)</p> <p>X CPD (04E.3) / PLS (09G.P) (国五<sup>1</sup>) (AQ160-ECO-Rowi)</p> <p>Y DLX (04E.8) / SJZ (02T.S) SSR (国五<sup>1</sup>) (Rowi)</p> <p>Z DLX (04E.8) / SXK (09G.R) SSR (国五<sup>1</sup>) (Rowi)</p> <p>0 DLX (04E.8) / SJZ (02T.S) SSR (国五<sup>2</sup>)</p> <p>1 DLX (04E.8) / SXK (09G.R) SSR (国五<sup>2</sup>)</p> <p>2 DLF (04E.8) / SJZ (02T.S) SSR (国六) (Rowi)</p> <p>3 DLF (04E.8) / SXK (09G.R) SSR (国六) (Rowi)</p> <p>4 DLF (04E.8) / SJZ (02T.S) SSR (国六)</p> <p>5 DLF (04E.8) / SXK (09G.R) SSR (国六)</p> <p><b>车型系列: 斯柯达(SKODA)YETI多用途乘用车</b></p> <p>A CSS (04E.H) / OFA (0A4.C) (京V)</p> <p>B CSS (04E.H) / PTK (0AM.U) (京V)</p> <p>C CSR (04E.3) / PNQ (0AH.M) (国五<sup>2</sup>)</p> <p>D CEA (06J.4) / POU (02E.4) (京V)</p> <p>E CSS (04E.H) / OFA (0A4.C) (国五<sup>1</sup>)</p> <p>F CSS (04E.H) / PTK (0AM.U) (国五<sup>1</sup>)</p> <p>G CEA (06J.4) / POU (02E.4) (国五<sup>1</sup>)</p> <p>H CSS (04E.H) / OFA (0A4.C) (国五<sup>2</sup>)</p> <p>J CSS (04E.H) / PTK (0AM.U) (国五<sup>2</sup>)</p> <p>K CEA (06J.4) / POU (02E.4) (国五<sup>2</sup>)</p> <p>L CEA (06J.4) / POU (02E.4) (国五<sup>2</sup>) (YH)</p> <p><b>车型系列: 斯柯达(SKODA)RAPID(Spaceback)轿车</b></p> <p>A CST (04E.H) / QFP (0AM.V) (国五<sup>1</sup>)</p> <p>B CPD (04E.3) / NJV (02T.R) (国五<sup>1</sup>)</p> <p>C CPD (04E.3) / PLS (09G.P) (国五<sup>1</sup>)</p> <p>D CPD (04E.3) / NJV (02T.R) (国IV)</p> <p>E CPD (04E.3) / PLS (09G.P) (国IV)</p> <p>F CST (04E.H) / QFP (0AM.V) (国五<sup>2</sup>)</p> <p>G CPD (04E.3) / NJV (02T.R) (国五<sup>2</sup>)</p> <p>H CPD (04E.3) / PLS (09G.P) (国五<sup>2</sup>)</p> <p>J CKA (04E.1) / NJS (02T.V) (国IV)</p> <p>K CKA (04E.1) / NJS (02T.V) (国五<sup>2</sup>)</p> <p>L CKA (04E.1) / NJS (02T.V) (国五<sup>2</sup>) (Rowi)</p> <p>M CPD (04E.3) / NJV (02T.R) (国五<sup>2</sup>) (Rowi)</p> <p>N CPD (04E.3) / PLS (09G.P) (国五<sup>2</sup>) (AQ160-ECO)</p> <p>P CPD (04E.3) / PLS (09G.P) (国五<sup>2</sup>) (AQ160-ECO-Rowi)</p> <p>R DLX (04E.8) / SJZ (02T.S) SSR (国五<sup>2</sup>) (Rowi)</p> <p>S DLX (04E.8) / SXK (09G.R) SSR (国五<sup>2</sup>) (Rowi)</p> <p>T DLF (04E.8) / SJZ (02T.S) SSR (国六) (Rowi)</p> <p>U DLF (04E.8) / SXK (09G.R) SSR (国六) (Rowi)</p> <p><b>车型系列: 斯柯达(SKODA)OCTAVIA NF/PA轿车(SK3710)</b></p> <p>A CSR (04E.3) / PSU (02T.R) (国五<sup>1</sup>)</p> <p>B CSR (04E.3) / PLS (09G.P) (国五<sup>1</sup>)</p>

FAHRZEUG-IDENTIFIZIERUNGSNUMMER

FÜR SAIC VOLKSWAGEN

版本: 4.15  
VERSION:

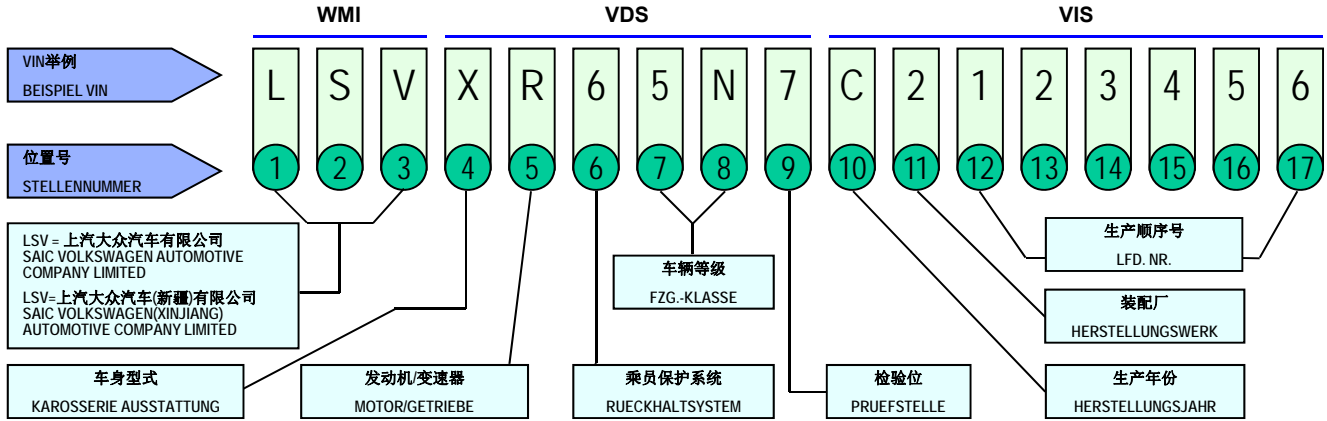

5 发动机/变速器 MOTOR/GETRIEBE		
C CSS (04E.H) / PCH (04A.C) (国五)	G DAH (04E.1) / QNM (02T.K) (国五) (Rowi)	L DJS (04E.H) / FD7DW004 (0DW.D) SSR (国六/PN <sup>11</sup> ) PSM
D CSS (04E.H) / QFP (0AM.V) (国五)	H DAH (04E.1) / PRZ (09G.R) (国五) (Rowi)	M DPL (06K.5) / FD7DW004 (0DW.D) SSR (国六/PN <sup>11</sup> ) PSM
E CSR (04E.3) / PSU (02T.R) (国五)		N DKX (06K.6) / AD7DL004 (0DL.6) SSR (国六/PN <sup>11</sup> ) PSM
F CSR (04E.3) / PLS (09G.P) (国五)	<b>车型系列: 斯柯达(SKODA)SUPERB NF/PA轿车(SK481/0)</b>	R DPL (06K.5) / DQ381-7F (0DW.D) SSR/4M (国六/PN <sup>11</sup> ) PSM
G CSS (04E.H) / PCH (04A.C) (国五)	A CSS (04E.H) / RING (04A.C) (国五)	R DKX (06K.6) / AD7DW003 (0DW.1) DQ381 (国六/PN <sup>11</sup> ) PSM
H CSS (04E.H) / QFP (0AM.V) (国五)	B CSS (04E.H) / QTB (0CW.C) (国五)	S DTH (06S.A) / FD7DW004 (0DW.D) SSR (国六/RDE)
J CSS (04E.H) / PCH (04A.C) SSR (国五)	C CSS (04E.H) / RING (04A.C) SSR (国五)	T DTH (06S.A) / FD7DW004 (0DW.D) SSR/4M (国六/RDE)
K CSS (04E.H) / QFP (0AM.V) SSR (国五)	D CSS (04E.H) / QTB (0CW.C) SSR (国五)	U DTJ (06S.B) / AD7DW003 (0DW.1) DQ381 (国六/RDE)
L DBW (04E.H) / QJL (0CW.C) (国五)	E CUF (06K.G) / RFT (0DE.A) (国五)	V DSV (05E.F) / FD7DW001 (0DW.C) SSR (国六/RDE)
M CSS (04E.H) / QTB (0CW.C) (国五) (40g/cft)	F CUF (06K.G) / RFT (0DE.A) SSR (国五)	W DXJ (04E.P) / FD6DD002 (0DD.C) SSR (国六/mil RDE)
N CSS (04E.H) / SNB (0CW.C) SSR (国五) (40g/cft)	G CUG (06K.H) / RFT (0DE.A) (国五)	[EBB(85kW)/BATTYPV49(350V/37Ah)]
P DJN (04E.K) / SNC (0CW.C) SSR (国五)	H CUG (06K.H) / RFT (0DE.A) SSR (国五)	X DUK (04E.P) / FD6DD002 (0DD.C) SSR (国六/PN <sup>11</sup> )
R DJN (04E.K) / SNC (0CW.C) SSR (国五) (Rowi)	J DKX (06K.6) / DQ381 (0DL.C) SSR (国六) (Rowi)	[EBB(85kW)/BATTYPV17(350V/37Ah)] UABC
S CSS (04E.H) / SNB (0CW.C) SSR (国五) (Rowi)	K DJS (04E.H) / FD7CW001 (0CW.C) SSR (国六/PN <sup>12</sup> )	Y DUK (04E.P) / FD6DD002 (0DD.C) SSR (国六/PN <sup>11</sup> )
T DLS (04E.K) / SNC (0CW.C) SSR (国六) (Rowi)	L DKV (06K.5) / DQ381 (0DL.C) SSR (国六/PN <sup>12</sup> )	[EBB(85kW)/BATTYPV17(350V/37Ah)] CATL
U DJS (04E.H) / SNB (0CW.C) SSR (国六) (Rowi)	M DKX (06K.6) / DQ381 (0DL.C) SSR (国六/PN <sup>11</sup> )	Z DJZ (04E.H) / FD6DD002 (0DD.C) SSR (国五)
V DLW (04E.8) / SJZ (02T.S) SSR (国五) (Rowi)	N CUF (06K.G) / RFT (0DE.A) (国五) (Rowi)	[EBB(85kW)/BATTYPV15(350V/34.7Ah)]
W DLW (04E.8) / SXX (09G.R) SSR (国五) (Rowi)	P CUF (06K.G) / RFT (0DE.A) SSR (国五) (Rowi)	1 DTH (06S.A) / FD7DW004 (0DW.D) SSR (国六/RDE) H-ECU
X DMB (04E.8) / SJZ (02T.S) SSR (国六) (Rowi)	R CUG (06K.H) / FD7DE002 (0DE.B) SSR (国五) (Rowi)	2 DTH (06S.A) / FD7DW004 (0DW.D) SSR/4M (国六/RDE) H-ECU
Y DMB (04E.8) / SXX (09G.R) SSR (国六) (Rowi)	S DPL (06K.5) / DQ381 (0DL.C) SSR (国六/PN <sup>11</sup> )	3 DTJ (06S.B) / AD7DW003 (0DW.1) DQ381 (国六/RDE) H-ECU
Z CSS (04E.H) / SNB (0CW.C) SSR (国五) (S.Rowi)	T DJS (04E.H) / FD7CW001 (0CW.C) SSR (国六/PN <sup>11</sup> )	<b>车型系列: 大众汽车(VOLKSWAGEN)PHIDEON轿车/ PHEV插电式混合动力轿车(VW511/1)</b>
1 DLS (04E.K) / FD7CW001 (0CW.C) SSR (国六/PN <sup>11</sup> )	U DLE (04E.H) / FD7CW001 (0CW.C) SSR (国六/RDE)	A CYY (06L.L) / RKW (0CK.E) SSR (国五)
2 DJS (04E.H) / FD7CW001 (0CW.M) SSR (国六/PN <sup>11</sup> )	V DTH (06S.A) / FD7DW003 (0DW.D) SSR (国六/RDE)	B CUH (06L.C) / RKX (0CK.E) SSR (国五)
<b>车型系列: 大众汽车(VOLKSWAGEN)LAMANDO轿车(VW313/0)</b>	W DTJ (06S.B) / FD7DW003 (0DW.D) SSR (国六/RDE)	C DMJ (06L.V) / FD7CK002 (0CK.E) SSR (国六)常规悬架
A CST (04E.H) / QSX (04A.C) (国五)	X DTH (06S.A) / FD7DW003 (0DW.D) SSR (国六/RDE) H-ECU	D CRE (06E.K) / PXF (0B5.Q) SSR (国五)
B CST (04E.H) / QRV (0CW.C) (国五)	Y DLE (04E.H) / FD7CW001 (0CW.C) SSR (国六/RDE) PKO-0	E CPE (06H.M) / FAB8W004 (0BW.3) SSR (国五)
C CSS (04E.H) / QSX (04A.C) (国五)	Z DLE (04E.H) / FD7CW001 (0CW.C) SSR (国六/RDE) PKO-2	[TZ269XY(45kW)/BATTYPA19(382V/37.5Ah)]
D CSS (04E.H) / QRV (0CW.C) (国五)	<b>车型系列: 大众汽车(VOLKSWAGEN)TOURAN L 多用途乘用车(VW378/0)</b>	F DMJ (06L.V) / FD7CK002 (0CK.E) SSR (国六)空气悬架
E CUF (06K.G) / PVQ (0DE.A) (国五)	A CSS (04E.H) / RING (04A.C) SSR (国五)	<b>车型系列: 大众汽车(VOLKSWAGEN)TERAMONT (PA)/ TERAMONT X (PA)多用途乘用车(VW416/0)</b>
F CUF (06K.G) / PVQ (0DE.A) SSR (国五)	B CSS (04E.H) / QTB (0CW.C) SSR (国五)	A DBF (06K.P) / QJR (0DL.C) SSR (国五)
G CUG (06K.H) / RZK (0DE.A) SSR (国五)	C CUF (06K.G) / RFT (0DE.A) SSR (国五)	B CUG (06K.H) / QJO (0DL.6) SSR (国五)
H CST (04E.H) / QSX (04A.C) (国五) (40g/cft)	D CSS (04E.H) / RING (04A.C) SSR (国五) (40g/cft)	C DDK (03H.M) / QTD (0DL.7) SSR (国五)
J CST (04E.H) / QRV (0CW.C) (国五) (40g/cft)	E CSS (04E.H) / QTB (0CW.C) SSR (国五) (40g/cft)	D DKV (06K.5) / QJR (0DL.C) SSR (国六)
K CSS (04E.H) / QSX (04A.C) (国五) (40g/cft)	F CSR (04E.3) / PSU (02T.R) (国五)	E DPL (06K.5) / QJR (0DL.C) SSR (国六/PN <sup>11</sup> )
L CSS (04E.H) / QRV (0CW.C) (国五) (40g/cft)	G DJS (04E.H) / RING (04A.C) SSR (国六)	F DKX (06K.6) / QJO (0DL.6) SSR (国六)
M CST (04E.H) / QSX (04A.C) SSR (国五)	H DJS (04E.H) / FD7CW001 (0CW.M) SSR (国六)	G DPK (03H.M) / QTD (0DL.7) SSR (国六)
N CST (04E.H) / QRV (0CW.C) SSR (国五)	J DNC (04E.8) / SJZ (02T.S) SSR (国六) (Rowi)	H DPL (06K.5) / QJR (0DL.C) SSR (国六/PN <sup>12</sup> )
P CSS (04E.H) / QSX (04A.C) SSR (国五)	K DJS (04E.H) / FD7CW001 (0CW.M) SSR (国六/PN <sup>11</sup> )	J DME (03H.M) / QTD (0DL.7) SSR (国六/PN <sup>11</sup> )
R CSS (04E.H) / QRV (0CW.C) SSR (国五)	L DJS (04E.H) / FD7CW001 (0CW.M) SSR (国六/PN <sup>11</sup> ) S.Rowi	K DPL (06K.5) / FD7AK001 (0AK.A) SSR (国六/PN <sup>11</sup> ) PSM
S DJR (04E.H) / QSX (04A.C) SSR (国六)	M DUT (04E.H) / FD7CW001 (0CW.C) SSR (国六/RDE)	L DKX (06K.6) / AD7AK001 (0AK.1) SSR (国六/PN <sup>11</sup> ) PSM
T DJR (04E.H) / QRV (0CW.C) SSR (国六)	<b>车型系列: 大众汽车(VOLKSWAGEN)TIGUAN L多用途乘用车/ TIGUAN L PHEV (PA)插电式混合动力多用途乘用车(VW326/0/1)</b>	M DME (03H.M) / AD7AK001 (0AK.2) SSR (国六/PN <sup>11</sup> ) PSM
U DJS (04E.H) / QRV (0CW.C) SSR (国六)	A CSS (04E.H) / SDZ (02Q.N) SSR (国五)	N DTH (06S.A) / FD7AK001 (0AK.A) SSR (国六/RDE)
V DJR (04E.H) / FD7CW001 (0CW.C) SSR (国六/PN <sup>11</sup> )	B CSS (04E.H) / SGE (0D9.G) SSR (国五)	P DTJ (06S.B) / AD7AK001 (0AK.1) SSR (国六/RDE)
W DSA (04E.9) / FD7CW001 (0CW.C) SSR (国六/PN <sup>11</sup> )	C CUF (06K.G) / SNG (0DE.B) SSR (国五)	R DME (03H.M) / AD7AK001 (0AK.2) SSR (国六/RDE)
X DJS (04E.H) / FD7CW001 (0CW.C) SSR (国六/PN <sup>11</sup> )	D DBF (06K.P) / SNG (0DE.B) SSR (国五)	S DKX (06K.6) / AD7AK001 (0AK.1) SSR (国六/PN <sup>11</sup> ) JZL
Y DSB (04E.9) / FD7CW001 (0CW.C) SSR (国六/PN <sup>11</sup> )	E CUG (06K.H) / QJO (0DL.6) SSR (国五)	T DME (03H.M) / AD7AK001 (0AK.2) SSR (国六/RDE) PKO
Z DJS (04E.H) / FD7CW001 (0CW.C) SSR (国六/PN <sup>11</sup> ) GTS	F DJS (04E.H) / DQ381 (0D9.G) SSR (国六)	U DTJ (06S.B) / AD7AK001 (0AK.1) SSR (国六/RDE) JZL
<b>车型系列: 斯柯达(SKODA)FABIA NF轿车(SK260/0)</b>	G DKV (06K.5) / DQ381 (0DL.C) SSR (国六)	V DTH (06S.A) / FD7AK001 (0AK.A) SSR (国六/RDE) H-ECU
A DAH (04E.1) / QNM (02T.K) (国五)	H DKX (06K.6) / DQ500 (0DL.6) SSR (国六)	W DTJ (06S.B) / AD7AK001 (0AK.1) SSR (国六/RDE) H-ECU
B DAH (04E.1) / PRZ (09G.R) (国五)	J DPL (06K.5) / FD7DW004 (0DW.D) SSR (国六/PN <sup>11</sup> )	X DTJ (06S.B) / AD7AK001 (0AK.1) SSR (国六/RDE) JZL/H-ECU
C CSR (04E.3) / QAA (02T.R) (国五)	K DJS (04E.H) / FD7DW004 (0DW.D) SSR (国六/PN <sup>11</sup> )	
D CSR (04E.3) / PLS (09G.P) (国五)		
E CSR (04E.3) / PLS (09G.P) (国五) (AQ160-ECO)		

Fahrzeug-Identifizierungsnummer

FÜR SAIC VOLKSWAGEN

版本: 4.15  
VERSION:

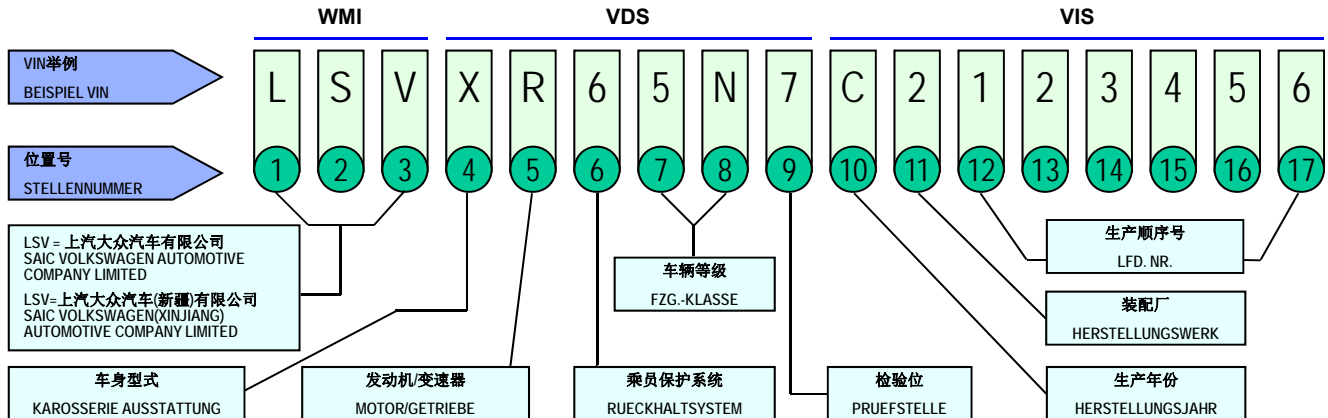

5 发动机/变速器 MOTOR/GETRIEBE		
<p><b>车型系列: 斯柯达(SKODA)KAROQ多用途乘用车(SK326/0)</b></p> <p>B DJN (04E.K) / SNB (0CW.C) SSR (国五<sup>2</sup>)                      C CSS (04E.H) / SNB (0CW.C) SSR (国五<sup>2</sup>)                      D DLS (04E.K) / DQ200 (0CW.C) SSR (国六)                      E DJS (04E.H) / FD7CW001 (0CW.M) SSR (国六/PN<sup>12</sup>)                      F DJS (04E.H) / FD7CW001 (0CW.M) SSR (国六/PN<sup>11</sup>)                      G DSB (04E.9) / FD7CW001 (0CW.M) SSR (国六/PN<sup>11</sup>)                      H DUT (04E.H) / FD7CW001 (0CW.M) SSR (国六/RDE)                      J DSB (04E.9) / FD7CW001 (0CW.M) SSR (国六/PN<sup>11</sup>)PKO</p> <p><b>车型系列: 斯柯达(SKODA)KODIAQ多用途乘用车(SK326/1)</b></p> <p>A CSS (04E.H) / SDZ (02Q.N) SSR (国五<sup>2</sup>)                      B CSS (04E.H) / SGE (0D9.G) SSR (国五<sup>2</sup>)                      C CUF (06K.G) / SNG (0DE.B) SSR (国五<sup>2</sup>)                      D DBF (06K.P) / SNG (0DE.B) SSR (国五<sup>2</sup>)                      E CUG (06K.H) / QJQ (0DL.6) SSR (国五<sup>2</sup>)                      F DJS (04E.H) / DQ381 (0DW.D) SSR (国六)                      G DKV (06K.5) / DQ381 (0DW.D) SSR (国六)                      H DKX (06K.6) / DQ500 (0DL.6) SSR (国六/PN<sup>11</sup>)                      J DPL (06K.5) / FD7DW004 (0DW.D) SSR (国六/PN<sup>11</sup>)                      K DJS (04E.H) / FD7DW001 (0DW.D) SSR (国六/PN<sup>11</sup>)                      L DKX (06K.6) / AD7DW003 (0DW.D) SSR (国六/PN<sup>11</sup>)                      M DPL (06K.5) / FD7DW004 (0DW.D) SSR (国六/PN<sup>11</sup>) S.Rowi                      N DKX (06K.6) / DQ381-7A (0DW.D) SSR (国六/PN<sup>11</sup>) S.Rowi                      P DTH (06S.A) / FD7DW004 (0DW.D) SSR (国六/RDE)                      R DTJ (06S.B) / AD7DW003 (0DW.D) SSR (国六/RDE)</p> <p><b>车型系列: 大众汽车(VOLKSWAGEN)LAVIDA NF(VW331/4/B) /GRAN LAVIDA NF(VW330/4)轿车/纯电动轿车</b></p> <p>A DLW (04E.8) / MQ200 (0AF.Z) SSR (国五<sup>2</sup>)                      B DLW (04E.8) / AQ160 (09G.R) SSR (国五<sup>2</sup>)                      C DJN (04E.K) / DQ200 (0CW.C) SSR (国五<sup>2</sup>)                      D CSS (04E.H) / DQ200 (0CW.C) SSR (国五<sup>2</sup>)                      E DMB (04E.8) / MQ200 (0AF.Z) SSR (国六)                      F DMB (04E.8) / AQ160 (09G.R) SSR (国六)                      G DLS (04E.K) / FD7CW001 (0CW.M) SSR (国六/PN<sup>12</sup>)                      H DJS (04E.H) / FD7CW001 (0CW.M) SSR (国六/PN<sup>12</sup>)                      J DLS (04E.K) / FD7CW001 (0CW.M) SSR (国六/PN<sup>11</sup>)                      K DJS (04E.H) / FD7CW001 (0CW.M) SSR (国六/PN<sup>11</sup>)                      L DSB (04E.9) / FD7CW001 (0CW.M) SSR (国六/PN<sup>11</sup>)                      M DLC (04E.K) / FD7CW001 (0CW.M) SSR (国六/RDE)                      N DLC (04E.K) / FD7CW001 (0CW.M) SSR (国六/RDE) PKO-0/H-ECU                      P DRZ (04E.8) / FA69G125 (09G.H) SSR (国六/RDE)                      R DSV (05E.F) / FD7CW005 (0CW.V) SSR (国六/RDE)                      S DLC (04E.K) / FD7CW001 (0CW.M) SSR (国六/RDE) PKO-2                      T DLE (04E.H) / FD7CW001 (0CW.M) SSR (国六/RDE)                      V EBD (100kW) / BATTYPV48(352V/125.3Ah/59Ah)(140W-hk/g)                      X EBD (100kW) / BATTYPV43/47(350V/113.6Ah)(125W-hk/g)                      Y EBD (100kW) / BATTYPV20/46(350V/108Ah)(120W-hk/g)                      Z EBD (100kW) / BATTYPV20(350V/99Ah)(105W-hk/g)</p> <p><b>车型系列: 大众汽车(VOLKSWAGEN)POLO NF(VW270/0)轿车</b></p> <p>A DMB (04E.8) / MQ200 (02T.S) SSR (国六)                      B DMB (04E.8) / AQ160 (09G.R) SSR (国六)                      C DRZ (04E.8) / FM5AF024 (02T.S) SSR (国六/RDE)                      D DRZ (04E.8) / FA69G126 (09G.R) SSR (国六/RDE)</p>	<p><b>车型系列: 斯柯达(SKODA)KAMIQ多用途乘用车(SK316/3)</b></p> <p>A DLX (04E.8) / SJZ (02T.S) (国五<sup>2</sup>)                      B DLX (04E.8) / SJZ (02T.S) SSR (国五<sup>2</sup>)                      C DLX (04E.8) / SXK (09G.R) SSR (国五<sup>2</sup>)                      D DLF (04E.8) / SJZ (02T.S) SSR (国六)                      E DLF (04E.8) / SXK (09G.R) SSR (国六)                      F DLS (04E.K) / DQ200 (0CW.C) SSR (国六/PN<sup>12</sup>)                      G DLS (04E.K) / DQ200 (0CW.C) SSR (国六/PN<sup>11</sup>)                      J DVM (04E.8) / FA69G125 (09G.R) SSR (国六/RDE)</p> <p><b>车型系列: 大众汽车(VOLKSWAGEN)THARU(VW316/5) 多用途乘用车</b></p> <p>A DJN (04E.K) / DQ200 (0CW.C) SSR (国五<sup>2</sup>)                      B DLS (04E.K) / DQ200 (0CW.C) SSR (国六)                      C CSS (04E.H) / DQ200 (0CW.C) SSR (国五<sup>2</sup>)                      D DJS (04E.H) / FD7CW001 (0CW.M) SSR (国六)                      E DKV (06K.5) / AD7DW001 (0DW.2) SSR (国六)                      F DPL (06K.5) / AD7DW001 (0DW.2) SSR (国六/PN<sup>11</sup>)                      G DLS (04E.K) / DQ200 (0CW.C) SSR (国六/PN<sup>11</sup>)                      H DJS (04E.H) / FD7CW001 (0CW.M) SSR (国六/PN<sup>11</sup>)                      J DSB (04E.9) / FD7CW001 (0CW.M) SSR (国六/PN<sup>11</sup>)                      K DSB (04E.9) / FD7CW001 (0CW.M) SSR (国六/PN<sup>11</sup>)PSM1                      L DTH (06S.A) / AD7DW001 (0DW.2) SSR (国六/RDE)                      M DPL (06K.5) / AD7DW001 (0DW.2) SSR (国六/PN<sup>11</sup>)PSM1                      N DTH (06S.A) / AD7DW001 (0DW.2) SSR (国六/RDE) H-ECU                      P DSV (05E.F) / FD7CW009 (0CW.U) SSR (国六/RDE)                      R DUT (04E.9) / FD7CW001 (0CW.M) SSR (国六/RDE)                      Z EBD(100kW)/BATTYPV37(352V/122Ah/60Ah)(135.7W-hk/g)</p> <p><b>车型系列: 大众汽车(VOLKSWAGEN)PASSAT NF轿车/ PHEV插电式混合动力轿车(VW421/1)</b></p> <p>A CSS (04E.H) / FD7CW001 (0CW.C) SSR (国五<sup>2</sup>)                      B DBF (06K.P) / FD7DE002 (0DE.B) SSR (国五<sup>2</sup>)                      C DJS (04E.H) / FD7CW001 (0CW.C) SSR (国六)                      D DKV (06K.5) / FD7DW003 (0DW.B) SSR (国六)                      E DKX (06K.6) / FD7DW003 (0DW.B) SSR (国六/PN<sup>11</sup>)                      F DPL (06K.5) / FD7DW003 (0DW.B) SSR (国六/PN<sup>11</sup>)                      G DJS (04E.H) / FD7CW001 (0CW.C) SSR (国六/PN<sup>11</sup>)                      H DJS (04E.H) / FD7CW001 (0CW.C) SSR (国六/PN<sup>11</sup>) WLTP                      J DLE (04E.H) / FD7CW001 (0CW.C) SSR (国六/RDE)                      K DTH (06S.A) / FD7DW003 (0DW.D) SSR (国六/RDE)                      L DTJ (06S.B) / FD7DW003 (0DW.D) SSR (国六/RDE)                      M DTH (06S.A) / FD7DW003 (0DW.D) SSR (国六/RDE) H-ECU                      N DTJ (06S.B) / FD7DW003 (0DW.D) SSR (国六/RDE) H-ECU                      P DLE (04E.H) / FD7CW001 (0CW.C) SSR (国六/RDE) PGM-0                      R DLE (04E.H) / FD7CW001 (0CW.C) SSR (国六/RDE) PGM-2                      X DXJ (04E.P) / FD6DD001 (0DD.B) SSR (国六/RDE)                      [EBB(85kW)/BATTYPV49(350V/37Ah)]                      Y DUJ (04E.P) / FD6DD001 (0DD.B) SSR (国六/PN<sup>11</sup>)                      [EBB(85kW)/BATTYPV17(350V/37Ah)]                      Z DJZ (04E.H) / FD6DD001 (0DD.B) SSR (国五<sup>2</sup>)                      [EBB(85kW)/BATTYPV15(350V/34.7Ah)]</p>	<p><b>车型系列: 大众汽车(VOLKSWAGEN)T-CROSS(VW216/0) 多用途乘用车</b></p> <p>A DMB (04E.8) / MQ200 (02T.S) SSR (国六)                      B DMB (04E.8) / AQ160 (09G.R) SSR (国六)                      C DLS (04E.K) / DQ200 (0CW.C) SSR (国六/PN<sup>11</sup>)                      D DJS (04E.H) / DQ200 (0CW.C) SSR (国六)                      E DMB (04E.8) / MQ200 (02T.S) SSR (国六/PN<sup>11</sup>)                      F DMB (04E.8) / AQ160 (09G.R) SSR (国六/PN<sup>11</sup>)                      G DJS (04E.H) / DQ200 (0CW.C) SSR (国六/PN<sup>11</sup>)                      H DLC (04E.K) / FD7CW001 (0CW.C) SSR (国六/RDE)                      J DRZ (04E.8) / FM5AF024 (02T.S) SSR (国六/RDE)                      K DRZ (04E.8) / FA69G126 (09G.R) SSR (国六/RDE)                      L DSV (05E.F) / FD7CW005 (0CW.V) SSR (国六/RDE)</p> <p><b>车型系列: 大众汽车(VOLKSWAGEN)VILORAN(VW418/2) 多用途乘用车</b></p> <p>A DKX (06K.6) / FD7DL002 (0DL.C) SSR (国六/PN<sup>11</sup>)                      B DPL (06K.5) / FD7DL002 (0DL.C) SSR (国六/PN<sup>11</sup>)                      C DPL (06K.5) / FD7AK001 (0AK.1) SSR (国六/PN<sup>11</sup>)                      D DKX (06K.6) / FD7AK001 (0AK.1) SSR (国六/PN<sup>11</sup>)                      E DTH (06S.A) / FD7AK001 (0AK.A) SSR (国六/RDE)                      F DTJ (06S.B) / FD7AK001 (0AK.A) SSR (国六/RDE)                      G DTH (06S.A) / FD7AK001 (0AK.A) SSR (国六/RDE)3RD                      H DTJ (06S.B) / FD7AK001 (0AK.A) SSR (国六/RDE)3RD</p> <p><b>车型系列: 斯柯达(SKODA)OCTAVIA A8轿车(SK381/0)</b></p> <p>A DJS (04E.H) / FD7CW001 (0CW.P) SSR (国六/PN<sup>11</sup>)                      B DLE (04E.H) / FD7CW001 (0CW.P) SSR (国六/RDE)                      C DLE (04E.H) / FD7CW001 (0CW.P) SSR (国六/RDE) PGM-0                      D DLE (04E.H) / FD7CW001 (0CW.P) SSR (国六/RDE) PGM-2</p> <p><b>车型系列: 大众汽车(VOLKSWAGEN)LAMANDO NF轿车(VW323/0)</b></p> <p>A DJS (04E.H) / FD7CW001 (0CW.P) SSR (国六/PN<sup>11</sup>)                      B DLE (04E.H) / FD7CW001 (0CW.P) SSR (国六/RDE)                      C DJS (04E.H) / FD7CW001 (0CW.P) SSR (国六/PN<sup>11</sup>) PGM                      D DLC (04E.K) / FD7CW001 (0CW.P) SSR (国六/RDE) H-ECU                      E DLE (04E.H) / FD7CW001 (0CW.P) SSR (国六/RDE) PGM-0/H-ECU                      F DLC (04E.K) / FD7CW001 (0CW.P) SSR (国六/RDE) PGM-0                      G DLC (04E.K) / FD7CW001 (0CW.P) SSR (国六/RDE) PGM-2                      H DLE (04E.H) / FD7CW001 (0CW.P) SSR (国六/RDE) PGM-2                      J DSV (05E.F) / FD7CW005 (0CW.V) SSR (国六/RDE)                      K DTJ (06S.B) / FD7DW003 (0DW.D) SSR (国六/RDE)</p> <p><b>车型系列: 大众汽车(VOLKSWAGEN)Entry NB(VW371/8)轿车</b></p> <p>A DRZ (04E.8) / FM5AF024 (02T.S) SSR (国六/RDE)                      B DRZ (04E.8) / FA69G125 (09G.R) SSR (国六/RDE)</p>

FAHRZEUG-IDENTIFIZIERUNGSNUMMER

FÜR SAIC VOLKSWAGEN

版本: 4.45  
VERSION:

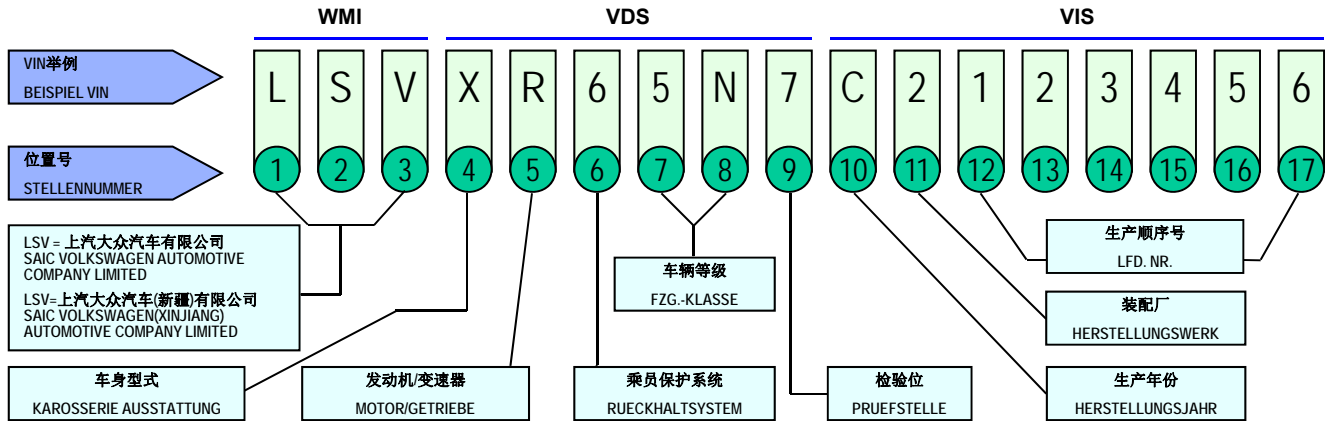

5 发动机/变速器 MOTOR/GETRIEBE	
<p><b>车型系列: 大众汽车(VOLKSWAGEN)MEB ID.4 X 纯电动多用途乘用车(VW316/6)</b></p> <p>A EBN(125kW) / BATTYPV30(55kWh/170W-h/kg)402km                      B EBN(150kW) / BATTYPV32(83.4kWh/175W-h/kg)                      C EBR/EBN(80kW/150kW) / BATTYPV32(83.4kWh/175W-h/kg)520km                      D EBN(125kW) / BATTYPV80(52.8kWh/155W-h/kg) PED                      E EBR/EBN(80kW/150kW) / ATTPV32(83.4kWh/175W-h/kg)561km</p> <p><b>车型系列: 大众汽车(VOLKSWAGEN)MEB ID.6 X 纯电动多用途乘用车(VW316/7)</b></p> <p>A EBP(132kW) / BATTYPV31(63.2kWh/172W-h/kg)436km                      B EBP(150kW) / BATTYPV32(83.4kWh/175W-h/kg)                      C EBR/EBP(80kW/150kW)/BATTYPV32(83.4kWh/175W-h/kg)510km                      D EBR/EBP(80kW/150kW)/BATTYPV32(83.4kWh/175W-h/kg)555km</p> <p><b>车型系列: 大众汽车(VOLKSWAGEN)MEB NEO ID.3 纯电动轿车(VW310/6)</b></p> <p>A EBN(125kW) / BATTYPV30(55kWh/170W-h/kg)                      B EBN(125kW) / BATTYPV80(52.8kWh/155W-h/kg) PED</p>	<p><b>车型系列: 奥迪(AUDI)A7L(Limousine)轿车(AU581/1)</b></p> <p>A DTK (06T.B) / FD7DN004 (0DN.C) SSR (国六/RDE)                      B DTK (06T.B) / AD7DP002 (0DP.A) SSR (国六/RDE)                      C DLZ (06M.C) / AD7HL001 (0HL.B) SSR (国六/RDE)                      D DTK (06T.B) / FD7DN004 (0DN.C) SSR (国六/RDE) H-ECU                      E DTK (06T.B) / AD7DP002 (0DP.A) SSR (国六/RDE) H-ECU</p> <p><b>车型系列: 奥迪(AUDI)MEB A+SUVe纯电动多用途乘用车(VW316/6)</b></p> <p>A EBP(132kW) / BATTYPV31(63.2kWh) 420                      B EBP(150kW) / BATTYPV32(83.4kWh) 560                      C EBR/EBP(80kW/150kW) / BATTYPV32(83.4kWh) 520km                      D EBR/EBP(80kW/150kW) / BATTYPV32(83.4kWh) 550km</p> <p><b>车型系列: 奥迪(AUDI)Q6(C SUV)多用途乘用车(AU516/3)</b></p> <p>A DVL (06Q.B) 170kW / AD7AK001 (0AK.1) SSR (国六/RDE)                      B DVL (06Q.B) 195kW / AD7AK001 (0AK.1) SSR (国六/RDE)                      C DME (03H.M) / AD7AK001 (0AK.2) SSR (国六/RDE)                      D DVL (06Q.B) 170kW / AD7AK001 (0AK.1) SSR (国六/RDE) H-ECU                      E DVL (06Q.B) 195kW / AD7AK001 (0AK.1) SSR (国六/RDE) H-ECU</p>

FAHRZEUG-IDENTIFIZIERUNGSNUMMER

FÜR SAIC VOLKSWAGEN

版本: 4.45  
VERSION:

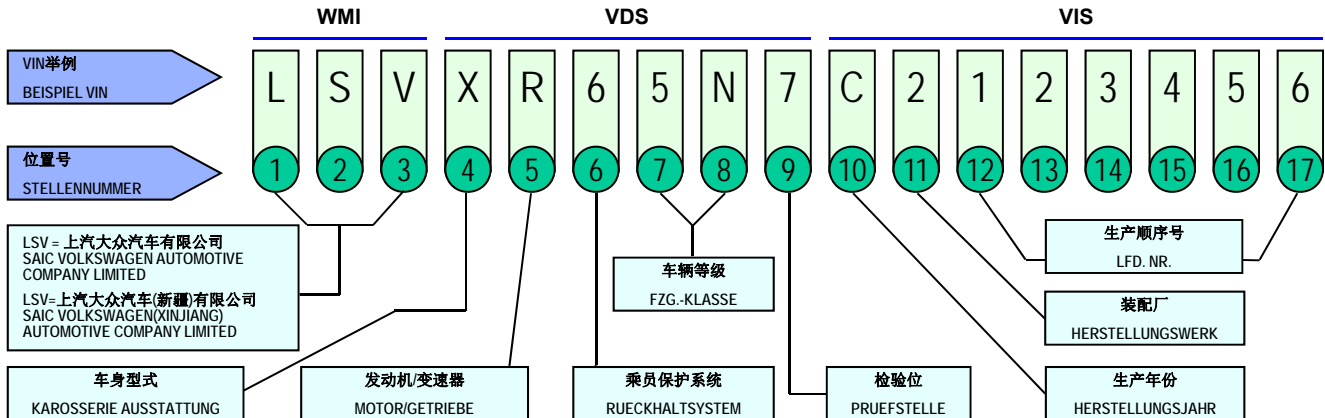

6 乘员保护系统 RUECKHALTSYSTEM	
0	安全带 ACTIVE BELTS
1	安全气囊(驾驶员) DRIVER DEPOWERED AIR BAG
2	安全气囊(驾驶员和副驾驶、前后侧面) DUAL DEPOWERED AIR BAGS, SIDE IMPACT BAGS FRONT
3	安全气囊(驾驶员和副驾驶、前后侧面) DUAL DEPOWERED AIR BAGS, SIDE IMPACT BAGS FRONT AND REAR
4	安全气囊(驾驶员和副驾驶) DUAL DEPOWERED AIR BAGS
5	安全气囊(驾驶员和副驾驶、前后座侧面、头部) DUAL DEPOWERED AIR BAGS, SIDE IMPACT BAGS FRONT AND REAR, HEAD BAGS
6	安全气囊(驾驶员和副驾驶、前后侧面、头部) DUAL DEPOWERED AIR BAGS, SIDE IMPACT BAGS FRONT, HEAD BAGS
7	安全气囊(驾驶员和副驾驶、前后座侧面、头部、膝部) DUAL DEPOWERED AIR BAGS, SIDE IMPACT AIR BAGS FRONT AND REAR, HEAD AIR BAGS, KNEE AIRBAG
8	安全气囊(驾驶员和副驾驶、前后侧面、头部、膝部) DUAL DEPOWERED AIR BAGS, SIDE IMPACT AIR BAGS FRONT, HEAD AIR BAGS, KNEE AIR BAG

7-8 车辆等级 FZG.-KLASSE	
33	上海桑塔纳轿车 SANTANA 上海桑塔纳旅行轿车 SANTANA VARIANT 上海桑塔纳2000轿车 SANTANA 2000 上海桑塔纳3000轿车 SANTANA 3000
9F	上海帕萨特轿车 PASSAT
9J	上海波罗轿车 POLO
5X	上海高尔轿车 GOL
1T	大众汽车(VOLKSWAGEN)TOURAN多用途乘用车
1Z	上海明锐轿车 OCTAVIA
18	大众汽车(VOLKSWAGEN)LAVIDA轿车
55	斯柯达(SKODA)Fabia轿车
3T	斯柯达(SKODA)SUPERB轿车
5N	大众汽车(VOLKSWAGEN)TIGUAN多用途乘用车
6R	大众汽车(VOLKSWAGEN)POLO轿车
A4	大众汽车(VOLKSWAGEN)NEW PASSAT/PASSAT GP轿车(VW411/1)
BR	大众汽车(VOLKSWAGEN)NEW SANTANA轿车(350/1)
NG	斯柯达(SKODA)RAPID轿车(SK351/1)
5L	斯柯达(SKODA)YETI多用途乘用车(SK316/0)
0G	斯柯达(SKODA)RAPID(Spaceback)轿车(SK350/3)
5E	斯柯达(SKODA)OCTAVIA NF轿车(SK371/0)
BM	大众汽车(VOLKSWAGEN)LAMANDO轿车(VW313/0)
0F	斯柯达(SKODA)FABIA NF轿车(SK260/0)
NP	斯柯达(SKODA)SUPERB NF轿车(SK481/0)
0R	大众汽车(VOLKSWAGEN)TOURAN NF多用途乘用车(VW378/0)
3E	大众汽车(VOLKSWAGEN)PHIDEON轿车/PHEV插电式混合动力轿车(VW511/1)
0T	大众汽车(VOLKSWAGEN)TIGUAN L (PA/X)多用途乘用车/PHEV插电式混合动力多用途乘用车(VW326/0/1)
CA	大众汽车(VOLKSWAGEN)TERAMONT /TERAMONT PA多用途乘用车(VW416/0) TERAMONT X (Coupe)/TERAMONT X (Coupe) PA多用途乘用车(VW416/1)
0Z	斯柯达(SKODA)KODIAQ (GT/PA)多用途乘用车(SK326/1)
0X	斯柯达(SKODA)KAROO多用途乘用车(SK326/0)
0N	斯柯达(SKODA)KAMIQ多用途乘用车(SK316/3)
0C	大众汽车(VOLKSWAGEN)LAVIDA NF/GRAN LAVIDA NF轿车(VW331/VW330)
0E	大众汽车(VOLKSWAGEN)LAVIDA NF BEV纯电动轿车(VW331/4)
B2	大众汽车(VOLKSWAGEN)THARU多用途乘用车(VW316/5)
C4	大众汽车(VOLKSWAGEN)PASSAT NF轿车/PHEV插电式混合动力轿车(VW421/1)
AW	大众汽车(VOLKSWAGEN)POLO NF轿车(VW270/0)
C1	大众汽车(VOLKSWAGEN)T-CROSS多用途乘用车(VW216/0)
C6	大众汽车(VOLKSWAGEN)WILORAN多用途乘用车(VW418/2)
E4	大众汽车(VOLKSWAGEN)MEB ID.4 X纯电动多用途乘用车(VW316/6)
E5	大众汽车(VOLKSWAGEN)MEB ID.6 X纯电动多用途乘用车(VW316/7)
E9	大众汽车(VOLKSWAGEN)MEB NEO (ID.3)纯电动轿车(VW310/6)
NX	斯柯达(SKODA)OCTAVIA A8轿车(SK381/0)
F2	奥迪(AUDI)A7L(Limousine)轿车(AU581/1)
G4	奥迪(AUDI)Q5 e-Tron纯电动多用途乘用车(AU316/3)
DM	大众汽车(VOLKSWAGEN)LAMANDO NF轿车(VW323/0)
G6	奥迪(AUDI)Q6/C SUV多用途乘用车(AU516/3)
DC	大众汽车(VOLKSWAGEN)Entry NB轿车(VW371/8)

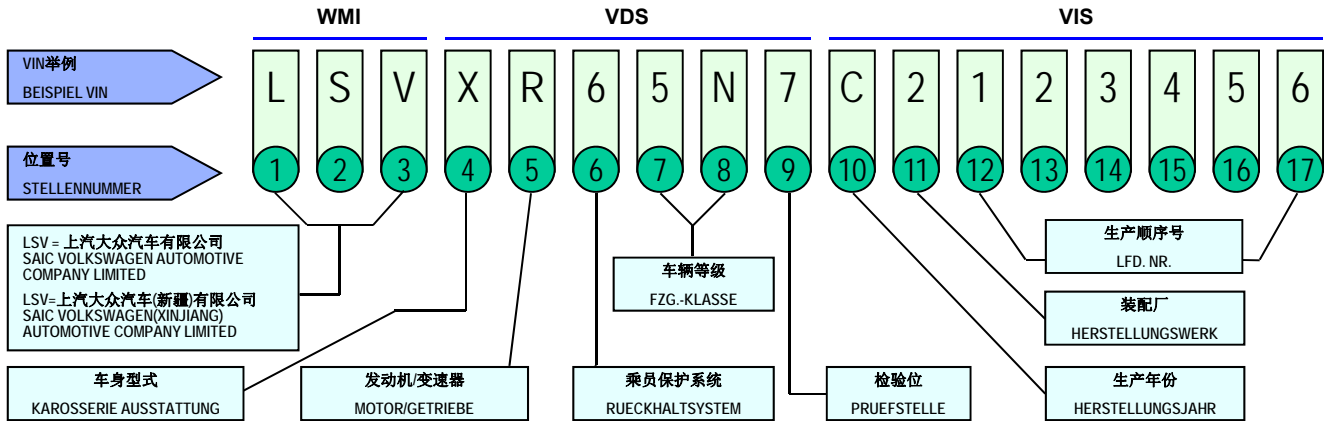

10 生产年份 HERSTELLUNGSJAHR							
年份 JAHR	代码 CODE	年份 JAHR	代码 CODE	年份 JAHR	代码 CODE	年份 JAHR	代码 CODE
2001	1	2011	B	2021	M	2031	1
2002	2	2012	C	2022	N	2032	2
2003	3	2013	D	2023	P	2033	3
2004	4	2014	E	2024	R	2034	4
2005	5	2015	F	2025	S	2035	5
2006	6	2016	G	2026	T	2036	6
2007	7	2017	H	2027	V	2037	7
2008	8	2018	J	2028	W	2038	8
2009	9	2019	K	2029	X	2039	9
2010	A	2020	L	2030	Y	2040	A

11 装配厂 HERSTELLUNGSWERK	
2	上汽大众汽车有限公司 (上海 安亭) SAIC VOLKSWAGEN AUTOMOTIVE COMPANY LIMITED (Shanghai Anting) 上汽大众汽车有限公司 新能源汽车分公司 (上海 安亭) SAIC VOLKSWAGEN AUTOMOTIVE COMPANY LIMITED MEB (Shanghai Anting)
N	上汽大众汽车有限公司 (江苏 南京/仪征) SAIC VOLKSWAGEN AUTOMOTIVE COMPANY LIMITED (Jiangsu Nanjing/Yizheng) 上汽大众汽车有限公司 (浙江 宁波) SAIC VOLKSWAGEN AUTOMOTIVE COMPANY LIMITED (Zhe.Jiang Ningbo) 上汽大众汽车有限公司 (湖南 长沙) SAIC VOLKSWAGEN AUTOMOTIVE COMPANY LIMITED (Hunan Changsha)
U	上汽大众汽车(新疆)有限公司 (新疆 乌鲁木齐) SAIC VOLKSWAGEN (XINJIANG) AUTOMOTIVE COMPANY LIMITED (Xinjiang Urumqi)